

产品规格书

PRODUCT SPECIFICATION

冷媒（制冷剂）泄漏监测传感器

Refrigerant Leakage Detection Sensor

U9601 Series Rev. A1



版本 Version	修订记录 Revision Record	发行日期 Issue Date
A0	初次发放 Initial Release	2023. 2. 15
A1	更新规格 Update the Specification	2023. 12. 20

1. 产品介绍 Product Introduction

1.1 产品概述 Product Description

U9601 Series是一款光学冷媒（制冷剂）泄漏监测传感器，其利用非色散红外（NDIR）原理探测空气中的制冷剂气体浓度。本产品采用优化的光学设计、电路设计、数字信号处理算法和补偿算法，相较于市场同类型产品，其具有信噪比高、重复性好、响应快的特点。此外，通过稳健性设计，产品通过了多项严苛的环境测试和寿命测试，具有优越的稳定性和可靠性。U9601 series is an optical-based refrigerant leakage detection sensor that utilizes the principle of non-dispersive infrared (NDIR) to detect refrigerant gas concentration in the air. The product series apply optimized optical design, circuit design, digital signal processing algorithm, and compensation algorithm. Compared with the like products in the market, it has the characteristics of high signal-to-noise ratio, good repeatability, and fast response. In addition, through the robust design, the product has passed several environmental and life tests that guarantee superior stability and reliability.

1.2 产品特性 Product Features

- ◇ 多温度点/全量程校准 Full-measurement-range calibration at multi-points temperature
- ◇ 零点噪声有效值小于10 ppm; RMS noise less than 10 ppm @ zero
- ◇ 使用寿命大于15年 Work-life more than 15 years
- ◇ 结构紧凑、便于安装 Compact mechanical structure for easy installation
- ◇ 提供自动校准模式和手动校准模式 Auto-calibration and Manual-calibration available
- ◇ 信号输出 PWM/UART/I2C; Output signal PWM/UART/I2C

1.3 应用领域 Application Field

- ◇ 家用空调的冷媒泄露监测 Refrigerant gas leakage monitoring of household HVAC system
- ◇ 商用空调的冷媒泄露监测 Refrigerant gas leakage monitoring of commercial HVAC system
- ◇ 车用空调的冷媒泄露监测 Refrigerant gas leakage monitoring of automotive HVAC system

1.4 使用注意事项 Application Notes

- a. 在传感器的焊接、安装、使用等过程中，应避免光学气室承受任何方向的压力；在操作时应采用防静电措施。During the soldering, installation, and use, avoid the optical chamber from pressure/stress in any direction; take ESD precautions during handling.
- b. 锡焊焊接时，温度设置须低于380 °C，尽量保证焊接时间小于3秒。选择性波峰焊可能导致热应力和光学气室形变，在工艺开发时应做充分验证。When performing tin soldering, set the temperature below 380 °C, and the soldering time shall be less than 3 seconds as far as possible. Selective wave soldering may cause thermal stress and optical chamber deformation, which should be carefully qualified when conducting process development.
- c. 确保传感器通风良好，勿遮挡气体扩散孔（防水透气膜）。如在风道中，避免气流直吹气体扩散孔。传感器应避免阳光直射和热辐射。Ensure that the sensor is well ventilated and the air diffusion holes (particle filter) are not blocked. For example, avoid blowing direct airflow at the air diffusion hole when placing the sensor in the air duct. Protect sensor from direct sunlight and thermal radiation.
- d. 应避免接触腐蚀性气体，以免传感器性能和可靠性退化。Avoid exposure to corrosive gases as it would lead to sensor performance and reliability degradation.
- e. 传感器出厂默认开启自校准功能，默认校准周期是72小时。如传感器工作在长期不通风的环境中，请通过指令关闭自校准功能。The auto-calibration function is enabled by default, and the default calibration period is 72 hours. If the sensor works in an unventilated environment, turn off the self-calibration function by sending a command.
- f. 通过引脚或校准命令进行手动校准时，传感器须在稳定的气体环境(例如0 ppm)下连续工作2分钟以上。When perform manual calibration with the pin or the calibration command, the sensor shall operate continuously for more than 2 minutes in a stable gas environment (e.g., 0 ppm).

2. 产品特性 Product Characteristics

2.1 技术指标 Technical Specification

产品型号 Product Number	U9601 Series
检测气体 Target Gas	R32, R454A, R454B, R454C, R290 ^[1]
检测范围 Measurement Range	0~50% LFL (extended range to 100% LFL upon request ⁽³⁾)
检测精度 Accuracy	±2.5% LFL for standard range ±5% LFL for extended range ⁽²⁾
响应时间 Response Time	< 30 s ⁽⁴⁾
工作条件 Operation Conditions	-40 to 85 °C; 0~95% RH (Non-condensing)
存储条件 Storage Conditions	-40 °C~85 °C
供电电压 Power Supply	DC 4.75 V~5.25 V, Ripple voltage < 100 mV
平均工作电流 Average Current	< 50 mA
报警输出 Alarm Output	Digital High/Low
通讯接口 Communication Interface	UART (default) PWM (upon request ⁽³⁾) I2C (upon request ⁽³⁾)
产品寿命 Life Expectancy	15 years
长期稳定性 Long-term Stability	≤2% LFL
重量 Weight	5.7 grams

- (1) Contact Unitense for monitoring of other refrigerant belongs to A2L, A3 safety group.
 (2) Standard range: 0 to 25% LFL and -20 to 60 °C; Extended range: 25 to 50% LFL and -40 to 85 °C.
 (3) Contact Unitense for customized request.
 (4) Directly exposed to the refrigerant gas with concentration 25% LFL and Detection Threshold Limit Value set to 10% of LFL.

2.2 引脚定义 Pin Definition

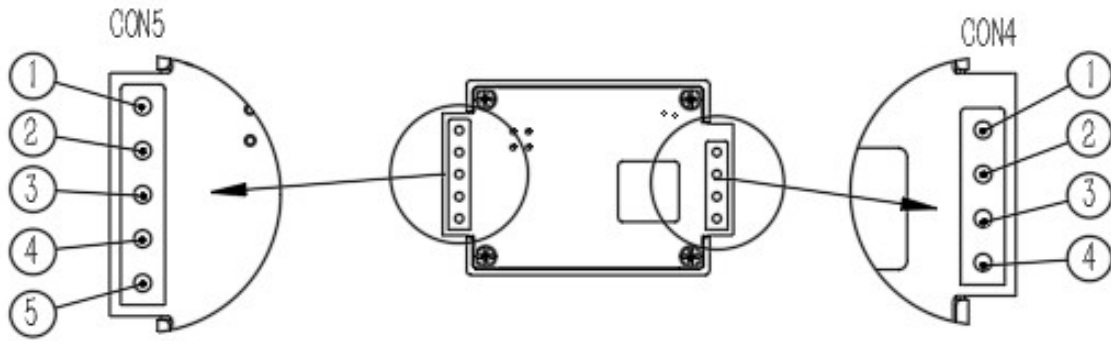

Bottom view from PCBA surface

序号 Pin-out		描述 Description
CON5	1	Manual calibration
	2	Output change from UART to IIC (upon request)
	3	UART_TX
	4	UART_RX
	5	DC +3.3 V output (upon request)
CON4	1	PWM output (upon request)
	2	Alarm output (upon request)
	3	GND
	4	DC +5 V power supply

2.3 数据传输 Data Communication

2.3.1 串口通信 Serial Port (UART) Communication

波特率Baud rate: 9600, 数据位Data Bits: 8, 停止位Stop Bits: 1, 校验位Parity: no, 流量控制Flow control: no

2.3.2 通讯协议格式 Format of Communication Protocol

发送-Send						
帧头	长度	命令	数据1	...	数据n	校验和
Head	Length	CMD	DATA1	...	DATAn	Checksum
0x10	xx	xx	xx	...	xx	xx
返回- Response						
帧头	长度	命令	数据1	...	数据n	校验和
Head	Length	CMD	DATA1	...	DATAn	Checksum
0x20	xx	xx	xx	...	xx	xx

2.3.3 通讯协议格式说明 Introduction about Format of Communication Protocol

项目 Items	描述 Description	字节数 Bytes
帧头 (Head)	发送是0x10, 返回是0x20。 Send 0x10 or Response 0x20.	1
长度 (Length)	帧数据字节长度, 等于CMD~DATAn的字节数。 Count of bytes from CMD to DATAn.	1
命令 (CMD)	详见命令列表。 See Command List.	1
数据 (DATAx)	DATA1~DATAn.	1Byte per DATAx
校验和 (CS)	CS = 256-(unsigned char)(Head+Length+CMD+DATA1+...+DATAn).	1

2.3.4 命令列表 Command List

命令列表 Command List	
0x01	读取软件版本号 Get software version
0x02	查询产品序列号 Get product serial number (SN)
0x03	读取气体浓度值 Read gas concentration
0x04	手动校准 Manual calibration
0x05	设置自动校准参数 Setting parameter of automatic calibration

2.3.5 指令格式 Command Format

0x01 - 读取软件版本号 Get software version						
发送命令 Send						
Byte0	Byte1	Byte2	Byte3			
Head	Length	CMD	CS			
0x10	0x01	0x01	0xEE			
返回值 Response						
Byte0	Byte1	Byte2	Byte3	...	Byten+2	Byten+3
Head	Length	CMD	DATA1	...	DATAn	CS
0x20	xx	0x01	xx	...	xx	xx
DATA1~DATAn为软件版本号, 内容和长度会随着软件版本的升级而改变。 DATA1~DATAn is software version. It will be changed with the software update.						

0x02 - 查询产品序列号 Get product serial number (SN)						
发送命令 Send						
Byte0	Byte1	Byte2	Byte3			
Head	Length	CMD	CS			
0x10	0x01	0x02	0xED			
返回值 Response						
Byte0	Byte1	Byte2	Byte3	...	Byte17	Byte18
Head	Length	CMD	DATA1	...	DATA15	CS
0x20	0x10	0x02	xx	...	xx	xx
DATA1~DATA15表示产品序列号,长度为15个字节。 DATA1~DATA15 is SN, 15 bytes.						

0x03 - 读取气体浓度值 Read gas concentration in ppm							
发送命令 Send							
Byte0	Byte1	Byte2	Byte3				
Head	Length	CMD	CS				
0x10	0x01	0x03	0xEC				
返回值 Response							
Byte0	Byte1	Byte2	Byte3	Byte3	Byte3	Byte5	Byte6
Head	Length	CMD	DATA1	DATA2	DATA3	DATA4	CS
0x20	0x05	0x03	xx	xx	xx	xx	xx
浓度读数 Concentration reading = (DATA1*256+DATA2)*10 (ppm) DATA3 and DATA4 are reserved.							

0x04 - 手动校准 Manual calibration of reading						
发送命令 Send						
Byte0	Byte1	Byte2	Byte3	Byte4	Byte5	
Head	Length	CMD	DATA1	DATA2	CS	
0x10	0x03	0x04	xx	xx	xx	
返回值 Response						
Byte0	Byte1	Byte2	Byte3			
Head	Length	CMD	CS			
0x20	01	0x04	0xDB			
校准目标值 Calibration target value = (DATA1*256+DATA2)*10 (ppm)						

0x05 - 设置自动校准参数 Setting parameter of automatic calibration

发送命令 Send

Byte0	Byte1	Byte2	Byte3	Byte4	Byte5	Byte6	Byte7	Byte8
Head	Length	CMD	DATA1	DATA2	DATA3	DATA4	DATA5	CS
0x10	0x06	0x05	xx	xx	xx	xx	xx	xx

返回值 Response

Byte0	Byte1	Byte2	Byte3
Head	Length	CMD	CS
0x20	01	0x05	0xDA

DATA1: 自动校准使能 Auto Calibration Function Enable, 1 - Enable, 0 - Disable.

DATA2 and DATA3: 自动校准周期 Auto Calibration Function Period (hours) = DATA2*256+DATA3.
This value will be set to 24H if it is less than 24H.

DATA4 and DATA5: 自动校准目标值 Auto Calibration target value
= (DATA4*256+DATA5)*10 (ppm)

3. 外形尺寸 Product Outlines (unit: mm)

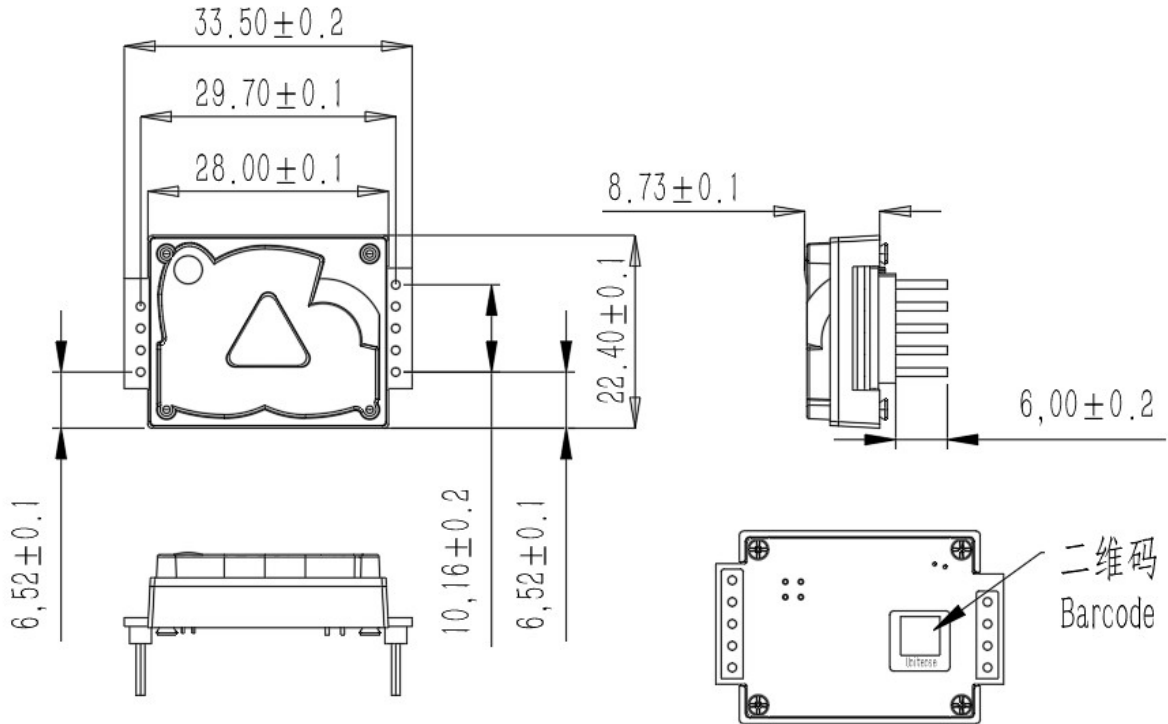

4. 包装规格 Packaging Specification

包装箱尺寸 Carton Size (W*L*H)			产品托盘数 Tray Qty.	每托盘产品数 Qty. per Tray	总数 Total Qty.	重量 Gross Weight
415 mm	355 mm	215 mm	8 pcs	72 pcs	576 pcs	Max.10.0 kg

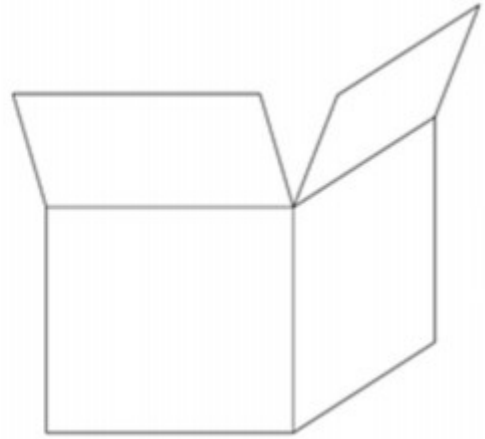
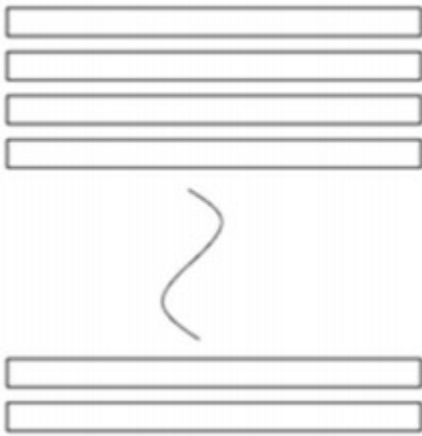

防静电吸塑托盘 Anti-static blister tray
数量 Qty.: 9 pcs

包装箱 Carton
1 pc

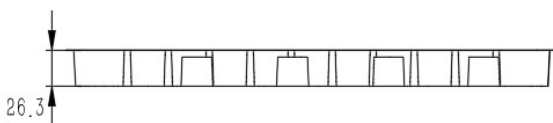
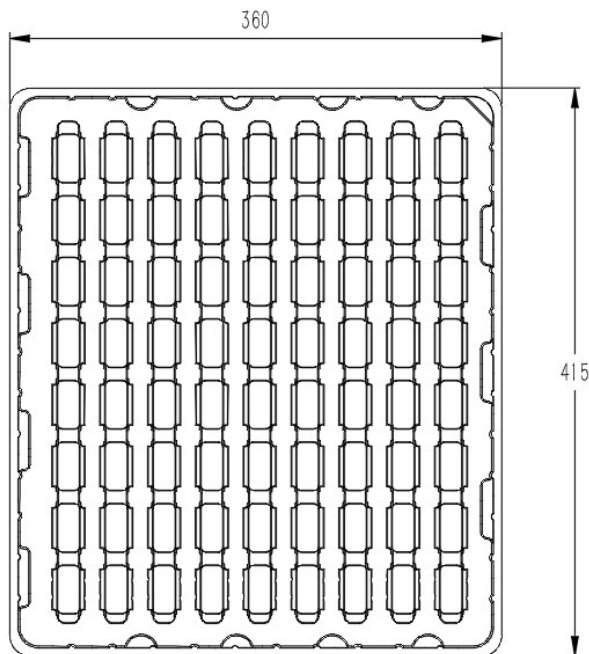

防静电吸塑托盘 Anti-static blister tray

注意:
 顶部放置1pc空置的防静电吸塑托盘
 充当盖板

Note:
 1pc empty anti-static blister tray serves
 as the cover on the top